

# HK 18 TP2

AERIAL PLATFORM



**HIDROKON**



*With Practical Solutions*









# **HK 18 TP2 Aerial Platform**

*With high quality equipment,  
superior capability and  
maximum safety features.*





## Technical Specifications

	Total weight*	5000 kg		Rotation angle of the basket	± 90°
	Max. working height	18 m		Size of the basket	700x1100x1400 mm
	Max. basket height	16 m		Max. basket load	225 kg
	Max. outreach	9 m	*It Varies Depending On The Vehicle Type.		
	Rotation angle of turntable	± 225°			

### BASIC SPECIFICATIONS

ENGINE START/STOP IN CABIN STANDARD

### BASKET

ENGINE START/STOP IN THE BASKET STANDARD

220 V AC OUTLET STANDARD

LIGHTENING STANDARD

### BOOMS

MAINBOOM ANGLE 85 °

LENGTH AND ANGLE CONTROL OF BOOMS STANDARD

### SLEWING

SLEWING ANGLE CONTROL STANDARD

SLEWING WITHIN THE VIEW OF THE SIDE MIRRORS STANDARD

### OUTTRIGGERS

VERTICAL JACKING CONTROL STANDARD

MAXIMUM PERMISSIBLE INCLINATION 1.5 °

### OPTIONAL SPECIFICATIONS

STABILIZER PADS OPTIONAL

## FEATURES



Joystick  
Control  
(Cabled)



Hand Pump



Intercom  
Easytalk



Wind  
Sensor



Basket  
Electrical  
Insulation



Automatic  
Outrigger  
Leveling



50%  
Outrigger  
Control  
System

## Dimensions (mm)

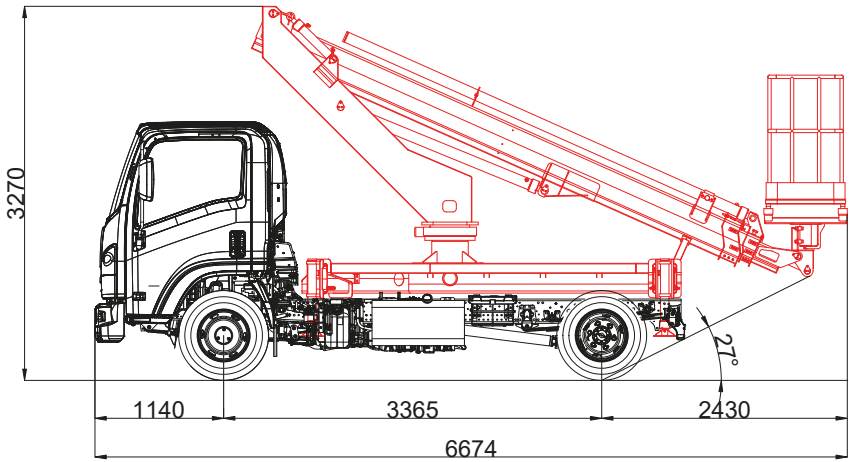

# HK 18 TP2 Working Diagrams

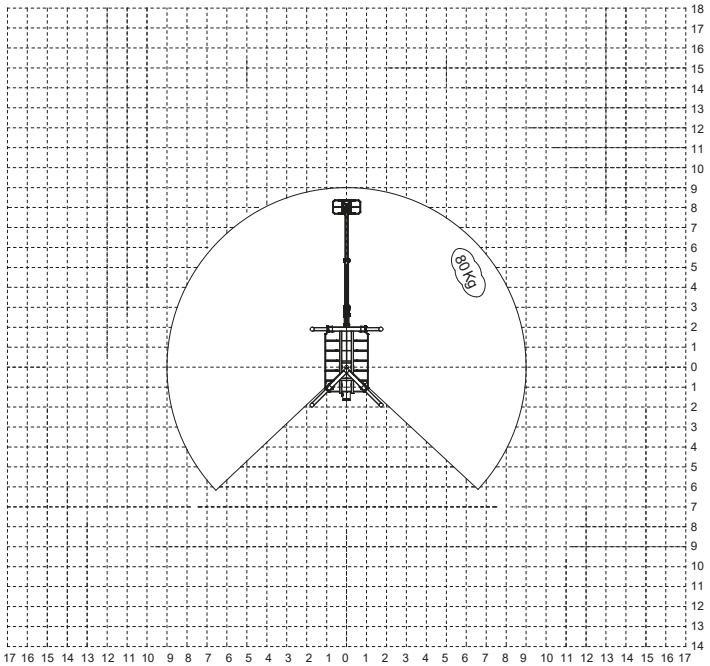
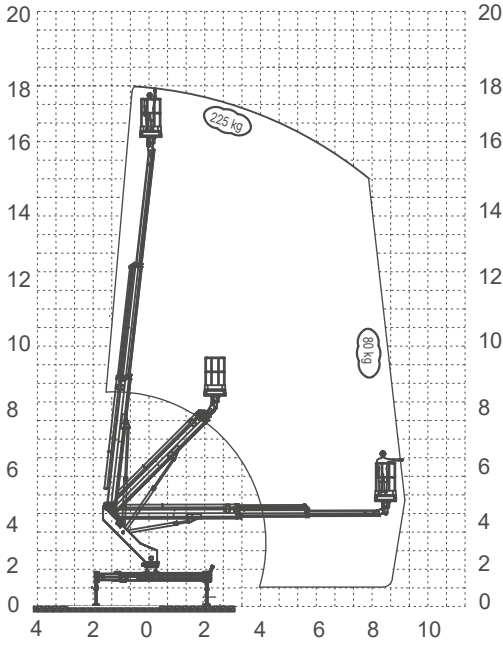

\*Boom deflections are not taken into consideration