

HK 180 40 T4

TELESCOPIC CRANE



HIDROKON



Power is With You!

HK 180 40 T4

Telescopic Crane

*With high quality equipment,
superior capability and
maximum safety features.*

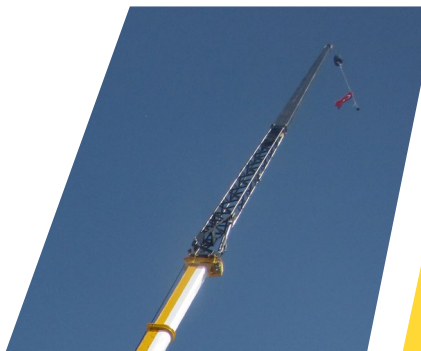



FEATURES



Operator
Cabin



Operator
Cabin
Heating



Operator
Cabin A/C



Joystick
Control



Operator
Cabin
(Tilttable)



Proportional
Control Valve



Crane
Radio Remote
Control



Outrigger
Radio Remote
Control



Automatic
Outrigger
Leveling



Outrigger
Control
System



KG
Load
Weighing
System



Variable
Displacement
Pump



Automatic
Lubrication



Counter
Weight

Specifications

Chassis

Frame

HIDROKON designed and manufactured, box type torsion resistant, made of high tensile structural steel.

Outriggers

X type four outriggers which are hydraulically operated by control levers. Control levers are located at the each side of the truck chassis.

Superstructure

Slewing System

Continuous slewing on ball bearing slewing ring. Process is operated by hydraulic motor driven planetary gear reducer. Slewing is possible continuously 360°.

- Slewing speed 1.5 min⁻¹

Operator Cabin

Ergonomic and comfortable design for optimum visibility. Cabin with heater and tilt function up to 25°.

Counterweight

Fixed counterweight of 8.3t.

Booms

Telescopic Booms

System consist of 1 basic boom and 3 telescopic boom sections. Hydraulically extendable and synchronized extension is on telescopic booms. Sections are made of high strength structural steel.

- Main boom length is 10.6 m – 38.5 m.
- Boom angle range is 0° - 82°.
- Main boom reaches 0° to 82° in 95 s.

Swing-away jib

Comprises of two section, a lattice and a welded structure.

- Offset angle range is 0°, 50°.
- Fixed length of the jib is 9.2 m / 16.2 m.

Safety Devices

Load Weighing System ,Load Moment System, anti-two block at boom head, pressure relief valves, dual overcenter valves.

System of the Display Screen consists of:

- Percentage of safe working limit that is utilized.
- Audible and visual pre-warning for overload, max lifting, back stop (warning in accordance with anti-two block switch) and pre-alarm (buzzer alarm when the %75 lifting capacity is reached).
- Entry log for number of parts of line.
- Screen showing main boom angle, boom length, load radius, rated lifting capacities, measured load values and permissible load.
- Net weight calculation in the case of equipment usage for load handling.
- User is able to update time & date. Furthermore total working time is able to be set.

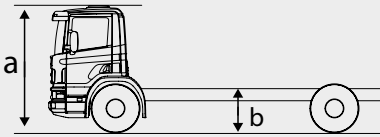

Crane Carrier

a: distance between carrier cab and floor level

b: distance between carrier chassis and floor level

8x4 vehicle, to be supplied by the customer.

Minimum wheelbase may vary depending on the vehicle.

Max a : 2920 mm

Max b : 1100 mm

General Notes

1. Load diagrams and load charts given only apply to the original HIDROKON manufactured models. Other party modifications or use of optional equipment may result in capacity reduction.
2. All the lifting capacities given are the maximum loads that are depending on the conditions when only the machine stands on steady supporting surface.
3. Load diagrams are set for %50 and %100 outrigger extension lengths. Crane may be used for load handling only when the outrigger extension is min %50 and any configuration in between %50 and %100, load diagram for %50 outrigger extension apply.

Critical Notes for Operational Safety

1. The load charts are calculated according to EN 13000.
2. Crane should only be operated for handling load purposes (operations stated in ISO 4301-1, crane group A1).
3. The lifting capacity is subject to the level of outrigger extension and position of the turret. Given lifting capacities are applicable for the back and sides of the truck.
4. Automatic outrigger leveling and geometric control system are optional specifications for the model. When the model does not have these two features, operator may work in front of the cab area. We do not recommend working with the main boom in front of the cab area. In the case of working in front of the cab area and / or on a surface where outrigger jacks are not balanced, all the responsibility belongs to the user.
5. Main winch capacity is 58 kN (5914 kg) per line. It should not be used to lift a load more than its capacity.

Dimensions (mm)

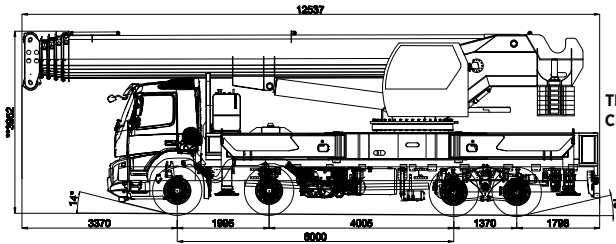

TRUCK: SCANIA P400 CB 8X4 Rigid
CRANE : HK 180 40 T4

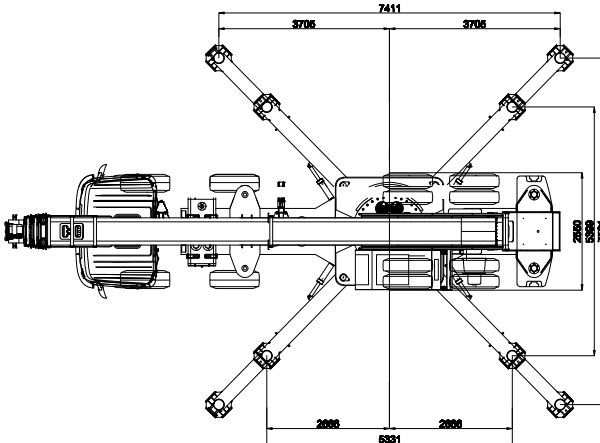

Technical Parameters

Category	Subject	Unit	Measure
Operating Performance	Max. technical lifting capacity	t	60
	Min. Rated working radius	m	3
	Basic boom max. height with load	m	10.6
	Main boom max. height with load	m	38.5
	Swing-away Jib max. height with load	m	58
Operating Speed	Winch hoist rope max. speed	m/min	0-102 (5th layer)
	Time for max. boom elevation	s	95
	Time for max. main boom extension	s	90
	Slewing speed	r/min	0-1.5
Dimensions	Outrigger extension (Lateral)	m	Fully extended: 7.411 Half extended: 5.331
	Outrigger extension (Longitudinal)	m	Fully extended: 7.521 Half extended: 5.399
	Swing-away Jib offset angle	°	0-50
	Main boom extension range	m	10.6 - 38.5
	Main boom angle range	°	0 - 82
	Swing-away jib length range	m	9.2 - 16.2

*Rope speed is valid when the min. oil flow rate is 150 l/min.

Hook Capacity	No. of Sheaves	No. Of lines	Weight (kg)	Notes
60t	5	10	390	Single hook

Layer	Hydraulic Winch		
	Operating (Rope) Speed	Lifting Capacity	
	m/min**	kN	kg
1st	37 / 74	78.6	8014
2nd	40 / 80	72.2	7362
3rd	44 / 88	66.8	6811
4th	47 / 94	62	6322
5th	81 / 102	58	5914

**When pump delivery is 150 l/min.

Wire Rope Layer	Drum	
	16 mm wire rope	
	Rope per layer (m)	Total Wire Rope (m)
1	35.5	35.5
2	38.5	74
3	42	116
4	45	161
5	49	210

Lifting Heights

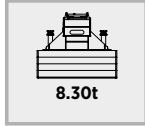
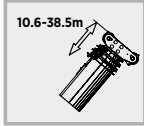
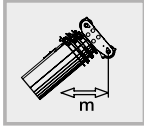
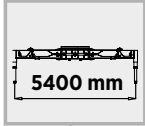

%50

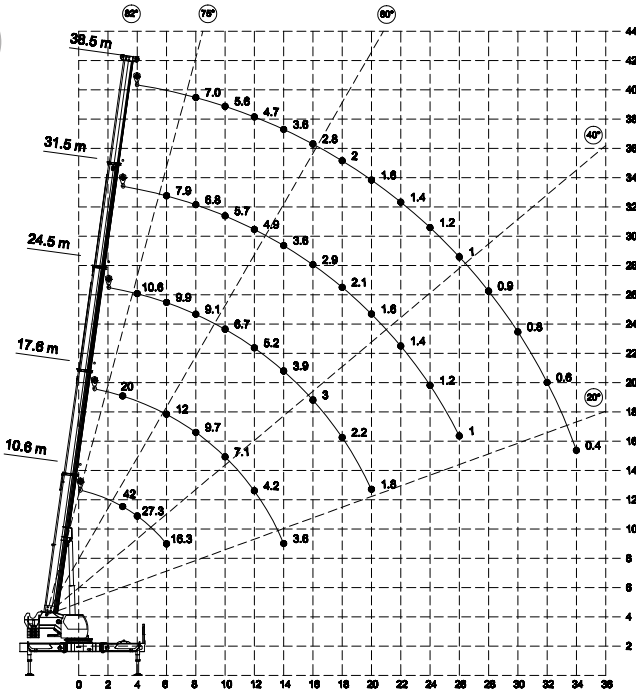

Boom Length	10.6 m	17.6 m	24.5 m	31.5 m	38.5 m
3 m	42.0	20.0			
4 m	27.3	17.3	10.6		
5 m		14.6	10.2		
6 m	16.3	12.0	9.9	7.9	
7 m		10.4	9.5	7.2	
8 m		9.7	9.1	6.8	7.0
9 m		8.5	7.8	6.2	6.2
10 m		7.1	6.7	5.7	5.6
11 m		5.7	5.8	5.2	5.0
12 m		4.2	5.2	4.9	4.7
13 m		3.8	4.5	4.2	4.1
14 m		3.6	3.9	3.6	3.6
15 m			3.3	3.2	3.1
16 m			3.0	2.9	2.8
17 m			2.6	2.5	2.4
18 m			2.2	2.1	2.0
19 m			2.0	1.9	1.8
20 m			1.8	1.6	1.6
21 m				1.5	1.5
22 m				1.4	1.4
23 m				1.3	1.3
24 m				1.2	1.2
25 m				1.1	1.1
26 m				1.0	1.0
27 m					0.95
28 m					0.9
29 m					0.85
30 m					0.8
31 m					0.7
32 m					0.6
33 m					0.5
34 m					0.4
Boom Length	10.6 m	17.6 m	24.5 m	31.5 m	38.5 m

Lifting Heights

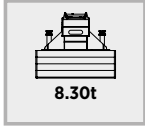
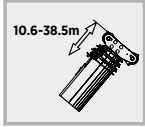
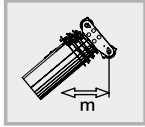

%100

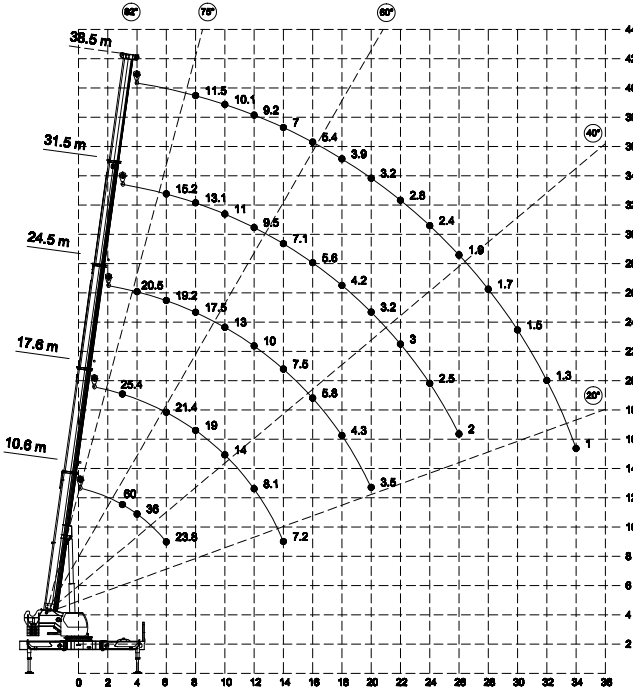

Boom Length	10.6 m	17.6 m	24.5 m	31.5 m	38.5 m
Radius					
3 m	60.0	25.4			
4 m	36.0	23.1	20.5		
5 m	29.5	22.2	19.7		
6 m	23.8	21.4	19.2	15.2	
7 m		20.1	18.3	14.0	
8 m		19.0	17.5	13.1	11.5
9 m		16.2	16.1	12.0	11.1
10 m		14.0	13.0	11.0	10.1
11 m		11.0	11.2	10.1	9.7
12 m		8.1	10.0	9.5	9.2
13 m		7.5	8.7	8.1	7.9
14 m		7.2	7.5	7.1	7.0
15 m			6.5	6.2	6.1
16 m			5.8	5.6	5.4
17 m			5.0	4.9	4.7
18 m			4.3	4.2	3.9
19 m			3.9	3.7	3.6
20 m			3.5	3.2	3.2
21 m				3.1	3.0
22 m				3.0	2.8
23 m				2.7	2.6
24 m				2.5	2.4
25 m				2.2	2.1
26 m				2.0	1.9
27 m					1.8
28 m					1.7
29 m					1.6
30 m					1.5
31 m					1.4
32 m					1.3
33 m					1.1
34 m					1.0
Boom Length	10.6 m	17.6 m	24.5 m	31.5 m	38.5 m

Lifting Jib Diagram

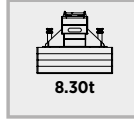
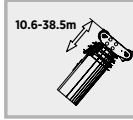
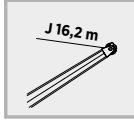
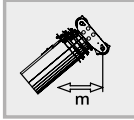

%100

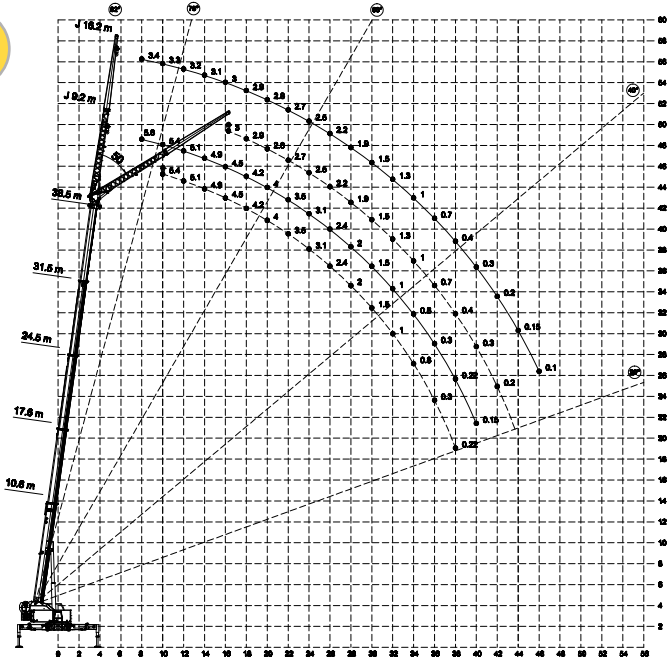

Boom Length	40 m Boom + 9.2 m Jib Jib Angle 32°		40 m Boom + 16.2 m Jib Jib Angle 82°	
	Load (ton)	Load (ton)	Load (ton)	Load (ton)
8 m		5.8		3.4
10 m	5.4	5.4		3.3
12 m	5.1	5.1		3.2
14 m	4.9	4.9		3.1
16 m	4.5	4.5	3.0	3.0
18 m	4.2	4.2	2.9	2.9
20 m	4.0	4.0	2.8	2.8
22 m	3.5	3.5	2.7	2.7
24 m	3.1	3.1	2.5	2.5
26 m	2.4	2.4	2.2	2.2
28 m	2.0	2.0	1.9	1.9
30 m	1.5	1.5	1.5	1.5
32 m	1.0	1.0	1.3	1.3
34 m	0.8	0.8	1.0	1.0
36 m	0.3	0.3	0.7	0.7
38 m	0.22	0.22	0.4	0.4
40 m		0.15	0.3	0.3
42 m			0.2	0.2
44 m				0.15
46 m				0.1

* Lifting values are calculated theoretically, values are subject to change by ± 5%.
 * Boom deflections are not taken into consideration.
 * The given values are not tested.