

# HK 24 TPA

ARTICULATED PLATFORM



**HIDROKON**



*With Practical Solutions*









# **HK 24 TPA** **Articulated Platform**

*With high quality equipment,  
superior capability and  
maximum safety features.*





## Technical Specifications

	Total weight*	5000 kg		Operating angle main boom	-20°, 80°
	Max. working height	23,8 m		Rotation angle of the basket	± 90°
	Max. basket height	21,8 m		Size of the basket	700x1100x1400 mm
	Max. outreach	10,7 m		Max. basket load	225 kg
	Rotation angle of turntable	± 360°	*It Varies Depending On The Vehicle Type.		

### BASIC SPECIFICATIONS

ENGINE START/STOP IN CABIN **STANDARD**

### BASKET

ENGINE START/STOP IN THE BASKET **STANDARD**

220 V AC OUTLET **STANDARD**

LIGHTENING **STANDARD**

### BOOMS

UPPER BOOM ANGLE **85°**

LENGTH AND ANGLE CONTROL OF BOOMS **STANDARD**

### SLEWING

SLEWING ANGLE CONTROL **STANDARD**

SLEWING WITHIN THE VIEW OF THE SIDE MIRRORS **STANDARD**

### OUTTRIGGERS

VERTICAL JACKING CONTROL **STANDARD**

MAXIMUM PERMISSIBLE INCLINATION **1°**

### OPTIONAL SPECIFICATIONS

STABILIZER PADS **OPTIONAL**

## FEATURES



Joystick  
Control  
(Cabled)



Hand Pump



Intercom  
Easytalk



Wind  
Sensor



Geometric  
Control  
System



Basket  
Electrical  
Insulation



Automatic  
Outrigger  
Leveling



50%  
Outrigger  
Control  
System

## Dimensions (mm)

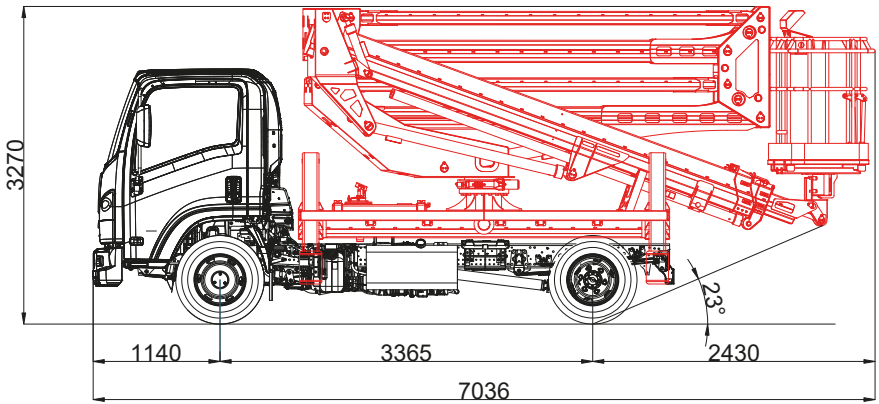

# HK 24 TPA Working Diagrams

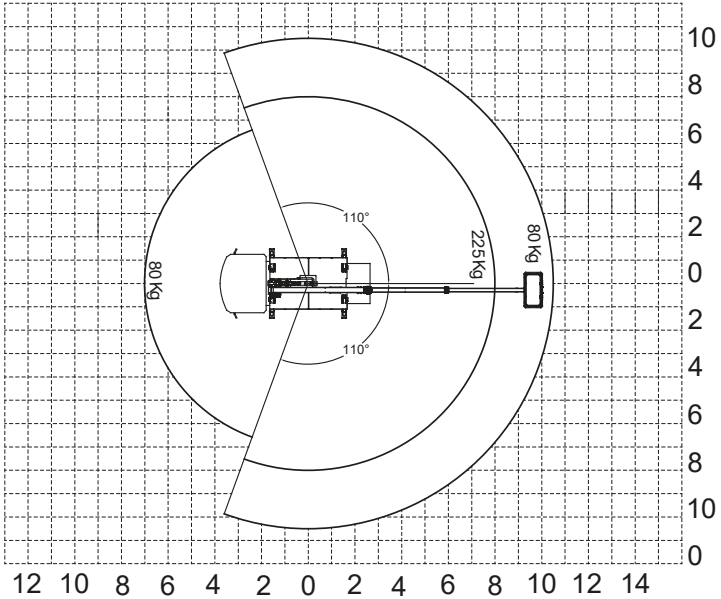
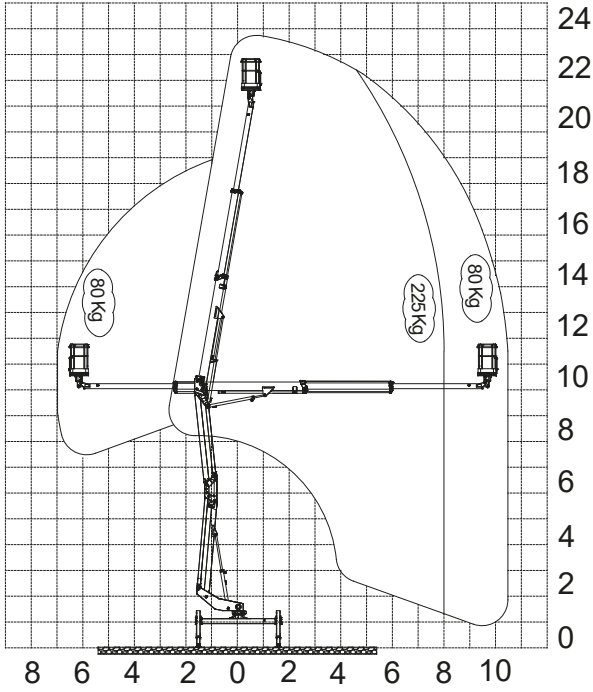

\*Boom deflections are not taken into consideration